

भारत सरकार केंद्रीय विद्युत प्राधिकरण दक्षिण क्षेत्रीय विद्युत समिति 29, रेसकोर्स क्रॉस रोड बेंगलूर- 560 009	 सत्यमेव जयते	Government of India Central Electricity Authority Southern Regional Power Committee 29, Race Course Cross Road Bengaluru-560 009	
Email: mssrpc-ka@nic.in	Web site: www.srpc.gov.in	Phone:080-22282516	
सं/No.	SRPC/SE(O)/BESS/2026-27/ 2449	दिनांक/ Date	12 th June 2026

सेवा मे / To

संलग्न सूची के अनुसार/ As per the enclosed list

Subject: Record Notes of Special Meeting of stakeholders to discuss the draft guidelines for Battery Energy Storage Systems held on 15.05.2026

महोदय /महोदया

Sir/ Madam,

In the 54th TCC and 57th SRPC meetings held on 16.03.2026 & 17.03.2026, the forum concluded that a committee comprising of field experts may be constituted to formulate Guidelines for Battery Energy Storage System (BESS) covering operational, protection and telemetry aspects.

Enclosed, please find attached the **Record Notes of the Special Meeting of stakeholders to discuss the draft guidelines for Battery Energy Storage Systems (BESS) held on 15.05.2026 (Friday)**. The meeting was hosted by KSEBL at **Moolamattom, Idukki in Hybrid mode**.

The guidelines finalized by the committee are attached.

The same is available on SRPC website (www.srpc.gov.in)

धन्यवाद / Thanking you,

भवदीय /Yours faithfully,

Mahesh 12/06/2026

अधीक्षक अभियंता(प्र) /Superintending Engineer (O)

1. Chief Engineer (GO), APTRANSCO, Vijayawada
2. Chief Engineer (Generation), APGENCO, Vijayawada
3. Chief General Manager (OCS, Civil, EA & CGRF works), APEPDCL, Visakhapatnam
4. Chief Engineer (E), SLDC, KPTCL, Bengaluru
5. Chief Engineer (ED), KPCL, Bengaluru
6. Joint Director (Projects), PCKL, Bengaluru (jdppckl2013@gmail.com)
7. Chief Engineer (TSO), KSEBL, Kalamaserry
8. Chief Engineer (Opn.), TANTRANSCO, Chennai
9. Chief Engineer (Mech), TNPGL, Chennai
10. CFC, TNPDL, Chennai
11. Chief Engineer (GO), TGTRANSCO, Hyderabad
12. Chief Engineer (Generation), TGGENCO, Hyderabad
13. Director (Operation, P&MM, IPC&RAC and Energy Audit), TGSPDCL, Hyderabad
14. Superintending Engineer - I, Electricity Department, Puducherry
15. General Manager (O&M), SRTS-I, PGCIL, Secunderabad.
16. General Manager (O&M), SRTS- II, PGCIL, Bengaluru.
17. General Manager (OS), SRHQ, NTPC, Secunderabad
18. AGM (EEMG), RSTPS, NTPC, Ramagundam
19. AGM(EEMG), Talcher STPS Stg - II, NTPC, Talcher
20. AGM (EEMG), Simhadri STPS, NTPC, Simhadri
21. AGM (EEMG), Kudgi STPS, NTPC, Kudgi.
22. General Manager, Telangana STPS, NTPC
23. General Manager(O&M), NTECL, Vallur
24. Chief General Manager, Neyveli TPS-II, Neyveli
25. General Manager, NNTPS, Neyveli
26. General Manager, TPS-I Expansion, Neyveli
27. General Manager, TPS-II Expansion, Neyveli
28. Chief General Manager (Ele), NLC Tamil Nadu Power Limited (NTPL), Tuticorin
29. Operation Superintendent, MAPS, Kalpakkam
30. STE (E&I), Kaiga G.S. Stage - I, Kaiga
31. STE (E&I), Kaiga G.S. Stage - II, Kaiga
32. Operation Superintendent, KKNPP, Kudankulam
33. AGM, JSWEL Vijayanagar Plant, Torangallu, Bellary
34. Associate Vice President (P&M), APL, Udupi, (Manoj.taunk@adani.com)
35. Head (O), SEIL Phase-I, Hyderabad
36. Head (O), SEIL Phase-II, Hyderabad
37. Plant Head, IL& FS Tamil Nadu Power Company Limited, Cuddalore
38. Sr.Vice President (O&M), HNPCL, Hyderabad
39. Sr. Deputy General Manager, CTUIL, Gurugram (anilsehra@powergrid.in)
40. Executive Director (Commercial), NPCIL, Mumbai (nrchoudhary@npcil.co.in)
41. Dy. General Manager, KNTL, IndiGrid Ltd, Noida (abhishek.kukreja@indigrid.com)
42. M/s Adani Enterprises Limited
43. Joint Sr. Vice President, Greenko Group, Hyderabad (venkateswarlu.a@greenkogroup.com)
44. General Manager, Renew Power Private Limited, Gurugram (yogesh.rao@renew.com,
manjunatha.h@renew.com, basappa.d@renew.com)
45. M/s Suzlon Energy Limited, New Delhi
46. Director, GM Division, CEA, New Delhi.
47. Director, NPC Division, CEA, New Delhi
48. Executive Director, NLDC, Grid-India, New Delhi.
49. Executive Director, SRLDC, Grid-India, Bengaluru

Record Notes of the Special Meeting of stakeholders to discuss the draft guidelines for Battery Energy Storage Systems (BESS) held on 15.05.2026

1. Introduction

- 1.1 In the 54th TCC and 57th SRPC meetings held on 16.03.2026 & 17.03.2026, the forum concluded that a committee comprising of field experts may be constituted to formulate Guidelines for Battery Energy Storage System (BESS) covering operational, protection and telemetry aspects. In this regard, a stakeholders' meeting was convened with participation of SLDCs, STUs and ISGS stations on 15.05.2026 in hybrid mode hosted by KSEBL at Moolamattom, Idukki, Kerala.
- 1.2 **Smt. Kavita C K, Dy. Chief Engineer, SLDC, KSEBL** welcomed Member Secretary, SRPC, Chief Engineer (Generation), KSEBL and all the participants to the meeting to discuss the draft guidelines for BESS
- 1.3 **Shri Viju Rajan John, Chief Engineer (Generation), KSEBL** expressed his honour in hosting the discussion and welcomed Shri Asit Singh, Member Secretary, SRPC, Smt. Malini N S, Superintending Engineer (O), SRPC, Shri M K Ramesh, Executive Director, SRLDC, and participants from SRPC, SRLDC, NTPC, SLDCs, STUs and GENCOs. He noted that integration of Battery Energy Storage Systems by the states is the need of the hour for the grid to mitigate the variability associated with RE generation and wished all the participants a fruitful and productive discussion.
- 1.4 **Shri Asit Singh, Member Secretary, SRPC** welcomed all participants to the special meeting convened to deliberate on the formulation of guidelines for the integration of Battery Energy Storage Systems (BESS) by the States. He informed that the meeting was a follow-up to discussions held during the 57th SRPC Meeting, wherein several CMDs of State utilities had highlighted the large-scale deployment of BESS at various locations within their respective States. It was felt that there is a need to develop comprehensive guidelines for the integration and optimal utilization of BESS installations, considering their deployment across different geographical locations within the State network. He further noted that the issue had been deliberated earlier to frame protection guidelines and a need was felt to formulate operational guidelines in consultation with stakeholders. Accordingly, SRPC had framed some guidelines, collected relevant information from Grid-India and compiled the inputs received from various stakeholders for discussion in the present meeting. He informed the participants that two presentations had been arranged as part of the deliberations. The first presentation would be made by REConnect on BESS optimization solutions for State utilities, and the second by Pace Digitek on Energy Management Systems (EMS) and Battery Management Systems (BMS). He expressed the hope that the presentations would facilitate meaningful discussions and invited participants to raise their questions and suggestions following the presentations. He stated that the issues identified for framing the guidelines would thereafter be deliberated upon in detail.
- 1.5 **Shri M. K. Ramesh, Executive Director, SRLDC**, welcomed the participants and appreciated the initiative taken by the Member Secretary, SRPC, in convening the meeting on the integration of Battery Energy Storage Systems (BESS). He observed that BESS integration is the need of the hour, particularly in view of the increasing challenges in meeting demand during non-solar hours. While solar generation effectively supports the system during daytime, energy storage systems are essential for addressing demand requirements during periods of low renewable generation. He noted that although Pumped Storage Projects (PSPs) provide a fast-response solution, their development is often constrained by environmental clearances, land acquisition requirements, and other challenges. He further stated that the integration of BESS into the grid requires careful planning and appropriate

technical standards. He emphasized that transmission planning studies should adequately consider the deployment of BESS and identify suitable locations where such systems can provide maximum operational benefits. He also highlighted the importance of deploying grid-forming inverter-based BESS at strategically identified locations, particularly where black-start capability may be required. Such installations could facilitate faster system restoration in the event of widespread disturbances or blackouts. He noted that BESS installations are gradually increasing in the Southern Region and expressed satisfaction at the growing interest among States in deploying energy storage systems. He remarked that the early commissioning of the planned BESS projects would strengthen system operations, particularly by supporting demand management during non-solar hours and enhancing overall grid reliability. He emphasized the need for detailed technical discussions and the formulation of appropriate standards and Standard Operating Procedures (SOPs) for the integration of BESS into the grid. He thanked the participants and wished the meeting fruitful deliberations.

- 1.6 Pace Digitek made a presentation on Energy Management Systems (EMS) and Battery Management Systems (BMS). Presentation is attached as **Annexure-A**
- 1.7 REConnect Energy made a presentation on BESS optimization solutions. Presentation is attached as **Annexure-B**
- 1.8 SRPC made a presentation on draft guidelines prepared in consultation with SRLDC and other stakeholders.
- 1.9 KSEBL presented the envisaged use cases under the draft guidelines, illustrating them through the operational experience of BESS projects in Kerala, including the upcoming 125 MW / 500 MWh BESS at Mylatti. Presentation is attached as **Annexure-C**

The following issues were discussed in the meeting:

2. Comments/Inputs of stakeholders

Topic: Regarding Pollution Control Board clearances for setting up BESS

APSLDC sought clarification regarding the statutory clearances required prior to synchronization of Battery Energy Storage Systems (BESS), particularly whether any additional clearances, apart from those applicable to Renewable Energy (RE) projects, are required for BESS installations.

It was clarified that all applicable safety regulations and statutory requirements must be complied with. Further, in case of absence of a separate First-Time Charging (FTC) procedure by the concerned utility, the procedure prescribed by Grid-India may be followed. It was also informed that the draft guidelines include a tentative list of requirements related to FTC and safety clearances.

APSLDC further raised concerns regarding obtaining clearances from the Pollution Control Board (PCB), noting that BESS projects do not appear to be explicitly covered under existing categories. In response, the forum observed that PCB-related requirements are generally associated with the disposal and recycling of batteries, whereas specific PCB clearance for commissioning a new BESS installation may not be required. However, it was emphasized that clearance from the Electrical Inspectorate is mandatory prior to commissioning.

The participants further noted that compliance with applicable fire safety standards and safety regulations is essential for BESS installations. MS, SRPC, observed that while requirements related to battery disposal

are understood, there is presently no confirmed position regarding the necessity of PCB clearance specifically for installation of BESS projects. It was agreed that any further clarification available on the matter would be shared with the stakeholders.

Topic: Thermal Runaway Protection for BESS

KPTCL suggested that the guidelines may include protection and monitoring requirements to ensure safe operation considering variations in thermal capability, particularly during charging, discharging, and utilization over repeated operating cycles.

MS, SRPC noted that the provisions related to safety, including safeguards against thermal runaway, are already covered under CEA (Measures related to Safety and Electric Supply) Amendment Regulation, 2026. It may be ensured that the same are complied with.

Issue: NPTC presentation on VGF Scheme for BESS

NTPC presented the status of Battery Energy Storage System (BESS) projects being implemented under the Viability Gap Funding (VGF) scheme of the Ministry of Power (Presentation is attached as **Annexure-D**). It was informed that the scheme envisages development of 30 GWh of BESS capacity across the country, of which 5 GWh has been allocated to NTPC. The projects are being implemented primarily to provide peaking power support to beneficiaries and to facilitate optimal utilization of existing generation and transmission infrastructure. NTPC further informed that the projects are being developed under different contractual models, with a commissioning timeline of 18 months linked to eligibility for VGF support.

NTPC presented the BESS projects already awarded under the scheme, including those located in the Southern Region, and highlighted that timely commissioning is critical as the VGF support is linked to adherence to the prescribed implementation schedule.

NTPC highlighted several regulatory, technical and operational issues requiring clarification:

- 1) **FTC Compliance at POI Level:** NTPC explained that, in order to minimize additional capital expenditure and optimize utilization of existing infrastructure, BESS installations are proposed to be connected at suitable points where transmission margins are available within the generating stations. NTPC stated that clarity is required on whether compliance with Frequency, Voltage and Reactive Power Control (FTC) requirements may be demonstrated at the BESS connection point or at the grid Point of Interconnection (POI), particularly in cases where the BESS is connected at lower voltage levels utilizing existing station infrastructure.
- 2) **BESS Scheduling Framework:** NTPC state that clarity is required regarding scheduling of integrated BESS projects, including the treatment of integrated versus standalone scheduling, DSM implications, charging and discharging schedules, and allocation of responsibilities among generators, beneficiaries and system operators.
- 3) **PPC and PQ Meter Locations:** NTPC highlighted the need for clear guidelines regarding the location of Plant Power Controller (PPC) and Power Quality (PQ) meters, particularly whether monitoring and control requirements should be established at the BESS connection point or at the grid connection point.
- 4) **Utilization for SRAS and TRAS:** NTPC expressed concerns regarding the utilization of VGF-funded BESS for Secondary Reserve Ancillary Services (SRAS) and Tertiary Reserve Ancillary Services (TRAS). It was submitted that extensive use of BESS for ancillary services could increase battery cycling and adversely affect battery life, whereas the VGF scheme envisages the BESS primarily for providing peaking support to beneficiaries.

5) **Peak Hour Discharge Requirement:** NTPC stated that the BESS projects are intended to provide peak-hour support and enhance thermal unit flexibility. Accordingly, appropriate operational provisions may be evolved to ensure availability of stored energy for discharge during peak demand periods while facilitating efficient charging during off-peak periods.

During the discussion, the forum observed that large-scale BESS integration is a relatively new area and that early regulatory and procedural clarity would facilitate smooth implementation. *It was suggested that NTPC proactively engage with CEA, CTU and Grid-India at an early stage to obtain necessary clarifications regarding connectivity, grid compliance, testing requirements, scheduling procedures and operational protocols. It was further noted that compliance studies, testing and certification activities may require considerable lead time and therefore should be initiated well in advance to avoid delays during commissioning.*

NTPC requested support from all stakeholders in resolving the identified issues within the implementation timeframe so as to ensure timely commissioning of the VGF-funded BESS projects and meet the stipulated commissioning deadlines.

Topic: Charging Strategy and Energy Procurement for NTPC's BESS Operations

KPTCL raised a query regarding a scenario wherein system demand remains high throughout the day and no opportunity is available for charging the BESS. NTPC stated that the thermal generating stations selected for the VGF-funded BESS projects were those with relatively high Energy Charge Rates (ECR) and a history of under-scheduling, thereby providing opportunities for charging the BESS during periods of backing down. NTPC further stated that pit-head stations were not considered, as they are generally scheduled at higher levels..

NTPC further stated that, in low-probability situations where generating units are scheduled at full capacity and adequate backing down is not available for charging the BESS, alternate mechanisms may be adopted, including procurement of power from the market during low-price periods such as during solar-rich hours.

MS, SRPC suggested that charging energy may also be sourced from beneficiaries through an appropriate framework, as the stored energy would ultimately be supplied back to the same beneficiaries during peak demand periods.

The forum observed that while one charge-discharge cycle may generally be feasible under prevailing system conditions, sustaining multiple cycles could become challenging depending on generation schedules and system conditions. NTPC noted that all-India demand presently varies significantly, ranging from about 190 GW to 240 GW, and that such variations, coupled with renewable generation patterns, are likely to provide sufficient opportunities for charging the BESS under most circumstances.

The need for a suitable operational framework addressing charging responsibility, scheduling arrangements and procurement of charging energy was emphasized. It was further observed that detailed operational procedures and guidelines governing charging and utilization of BESS under different system conditions are presently being evolved by NLDC and would address these operational aspects.

Additional Discussions

- ❖ **REMC, TN SLDC** emphasized on the need for ensuring protection co-ordination, under-frequency, over-frequency, under-voltage, over-voltage and fulfil the installation requirement of PMU and Harmonic Analysers as mandated by CEA.
- ❖ **SRPC** suggested future projects may be designed with sufficient flexibility to support DSM management, reserve management, market participation, ancillary services and other grid support applications.

It was suggested that future tenders may avoid restricting BESS utilization exclusively to peak shaving and may provide operational flexibility for additional applications.

- ❖ **SRLDC** highlighted the role of BESS in supporting grid stability through Fast Frequency Response (FFR), Primary Frequency Response (PFR), synthetic inertia and other advanced grid support functions was also discussed. It was observed that as large-scale battery capacity is added to the grid, suitable provisions should be incorporated to enable such capabilities wherever required as per grid.
- ❖ **Kerala** further informed that additional testing requirements may be necessary for BESS projects beyond the presently prescribed PPC testing procedures applicable to renewable energy plants, considering the additional operational capabilities of BESS.

3. Conclusion

SRPC sought the views of States/UT on the approach to be adopted for development of BESS operational applications and optimization tools, including whether such systems should be developed independently by individual States, or through a common platform, or with the support of third-party solution providers. SRPC, noted that in the long term, BESS assets may be utilized for multiple applications such as DSM management, renewable energy integration, demand forecasting, reserve management and market participation, for which a more comprehensive optimization platform may be beneficial.

Karnataka suggested for a common platform developed through a third-party solution provider.

Kerala observed that different States are adopting varying deployment methodologies and operational philosophies for BESS implementation. For instance, projects comprising multiple distributed BESS installations may necessitate centralized cloud-based management systems, whereas projects integrated at specific substations can be effectively operated through existing SCADA and control systems. In view of these differences, Kerala opined that a common application platform may not be required for all States, and the choice of solution should be based on the specific project architecture and operational requirements.

Kerala and PED requested that a standardized framework for Protection and Communication may be evolved. However, it was opined that implementation of a centralized EMS may be kept optional. It was opined that SAMAST may be leveraged for scheduling and optimization of BESS operations.

AP suggested for a commonly developed platform with customization option to meet the specific operational requirements of individual states.

TN informed that the matter would be examined internally and its views would be communicated subsequently. The inputs received subsequently is attached as **Annexure-E**.

MS, SRPC concluded that the views expressed by the States/UTs would be compiled and placed before TCC for further deliberation and necessary action. The finalized guidelines of the committee are attached.

The meeting concluded with thanks to all participants for their valuable contributions and active participation. Special thanks to KSEBL for hosting the meeting in hybrid mode and Pace Digitek, REConnect, NTPC and KSEBL for insightful presentations.

SOUTHERN REGIONAL POWER
COMMITTEE
GUIDELINES FOR BESS
INTEGRATION BY STATES IN
SOUTHERN REGION

May 2026

Southern Regional Power Committee

Guidelines for Integration and Operation of Battery Energy Storage Systems (BESS) by States

1. Introduction

In view of increasing penetration of renewable energy and the requirement for grid flexibility, Battery Energy Storage Systems (BESS) are being integrated into the grid. It is essential to define a uniform operational, protection, communication, and performance framework for BESS in line with grid security and reliability requirements.

2. Definitions

- i. Some of definitions from CERC Tariff Regulations (2nd Amendment) 2026 are given below (modified to meet this document):
 - a. 'Auxiliary energy consumption or 'AUX(bess)' means the quantum of energy consumed by auxiliary equipment of the battery energy storage system
Provided that the auxiliary energy consumption of the integrated energy storage system shall be measured separately for energy accounting.
 - b. 'Battery cell' means the electrochemical device of the battery energy storage system that stores electrical energy in chemical energy and converts chemical energy into electrical energy, which consists of a positive (cathode) and a negative (anode) electrode with the capability to generate electricity.
 - c. 'Battery cycle' in respect of a battery energy storage system means the charging of the battery from the depth of discharge to its maximum rating and discharging to its minimum specified rating equivalent to the depth of discharge to complete one cycle of a battery energy storage system: Provided "Depth of Discharge (DoD)" means the level to which a battery can be discharged relative to the maximum possible amount of energy that can be discharged by the battery in a single operational cycle, expressed as a percentage.
 - d. 'C-rate – charge or discharge rate' means the rate of discharge from or charging of the battery energy storage system, relative to its total capacity per hour and is expressed in terms of one-hour discharge as a fraction of C-rate.
- ii. Regulation 22(3) of IEGC Regulations 2023 state
22. TRIAL RUN OF GENERATING UNIT
.....
(3) Trial Run of Wind / Solar / ESS / Hybrid Generating Station
.....
(e) Successful trial run of a standalone Energy Storage System (ESS) shall mean one (1) cycle of charging and discharging of energy as per the design capabilities with the requisite metering, telemetry and protection system being in service.
.....

3. Operational Philosophy of BESS

3.1 General

SLDC shall have operational visibility and control over BESS connected to Intra-State Transmission System. BESS shall be treated as a **controllable grid resource**, capable of operating both as Load (during charging), Generator (during discharging).

3.2 Scheduling and Dispatch

As per the clause-43(3) of IEGC-2023

- *The SLDCs shall be responsible for optimum scheduling and despatch of electricity, monitoring of real time grid operations and management of the reserves including energy storage systems and demand response within its State control area, supervision and control over the intra-State transmission system, processing of interface energy meter data and coordinating the accounting and the settlement of State pool account, as may be specified by the appropriate State Commission.*

Accordingly, **Battery Energy Storage Systems (BESS)** shall be operated under the scheduling and dispatch framework of the SLDC. SLDC shall issue **charge and discharge schedules** for BESS for various modes as outlined below.

- BESS shall be included in
 - Day-Ahead Schedule (DAS)
 - Real-Time operations, wherever applicable.
- All deviations from the scheduled charge/discharge shall be accounted for as per the **applicable DSM Regulations**.

3.3 State of Charge (SoC) Management

- Operator shall maintain SoC within permissible band (generally 20–80%).
- Minimum reserve shall be maintained for:
 - Frequency response
 - Contingency support

3.4 Frequency Support

- BESS shall provide primary and fast frequency response as per CEA Connectivity Regulations.

3.5 Following are the possible BESS operations :

a) Frequency response

BESS can be used for providing Primary Frequency Response (PFR) or Fast Frequency Response (FFR).

If a control area is having less primary reserves, it can use the BESS for PFR.

FFR is mandatory for IBR technologies as per CEA Connectivity Regulations.

b) Reserve Management

If the Control Area is having less than mandated reserves it can be used for maintaining the Up/down reserves as applicable. These reserves should not be normally scheduled and will be used by System Operator to meet the contingencies.

c) DSM/ACE

States can use BESS for managing their DSM/ACE.

Operating philosophy

During the first volume limit of DSM or some defined quantum of ACE: BESS can come to 50% of (Max SoC – Min SoC) from the present SoC.

Between the first and second volume limit of DSM or some defined quantum of ACE: BESS can be used to counter the DSM/ACE at a smaller C rate

Beyond the second volume limit of DSM or some defined quantum of ACE: BESS can be used to counter the DSM/ACE at a highest C rate

d) Peak Demand Management

SLDC may finalise the input energy and output energy schedules for BESS block wise to meet the peak demand period considering the Aux Consumption, RTE, C rate etc.

e) Market based

BESS can operate as per DAM/RTM Rates.

f) During Congestion deployment by RLDC/NLDC

BESS to counter Congestion at highest C rate.

g) Evacuation/transmission constraint

BESS deployed to handle evacuation constraint or transmission constraint should primarily handle the constraint. If constraint is not there in real time it can be used for other purpose.

h) Reactive Power Support

BESS can be utilized to provide reactive power support in pockets of low/high voltage.

i) Black-start Capability

BESS equipped with grid-forming inverters can be utilized for Black Start support.

j) Manual entry by System Operator

BESS should be able to run to manual entry by System Operator.

As States are going for multiple BESS at various location the BESS despatch needs to be centrally managed through BESS optimiser at SLDC. This would avoid counter dispatches among BESS. BESS may be deployed to various in combination of the above. The objective functions may be defined first like Peak Demand Management and ACE or Peak Demand management and Market based etc and optimised schedules can be found out considering the limiting constraints.

4. Protection Requirements

As per clause-13(1) of Indian Electricity Grid Code 2023,

- *“All users connected to the integrated grid shall provide and maintain effective protection system having reliability, selectivity, speed and sensitivity to isolate faulty section and protect element(s) as per the CEA Technical Standards for Construction, the CEA Technical Standards for Connectivity, the CEA (Grid Standards) Regulations, 2010, the CEA Technical Standards for Communication and any other applicable CEA Standards specified from time to time”.*

Accordingly, **Battery Energy Storage Systems (BESS)** shall be equipped with adequate and coordinated protection systems to ensure safe and reliable operation. The BESS shall, at a minimum, be provided with the following protections:

- Overcurrent protection
- Differential protection (for transformer/feeder)
- Over/under voltage protection
- Over/under frequency protection
- Earth fault protection etc.

All protection systems shall be properly coordinated with the grid protection scheme to avoid mal-operation and ensure selective isolation of faults.

5. SCADA and Communication Requirements

As per Clause-3(11) of IEGC-2023, the developer/Entity shall provide:

- *Reliable speech and data communication systems shall be provided to facilitate necessary communication, data exchange, supervision and control of the grid by the NLDC, RLDC and SLDC in accordance with the CERC (Communication System for Inter-State Transmission of Electricity) Regulations, 2017 and the CEA Technical Standards for Communication.*
- *The associated communication system to facilitate data flow up to appropriate data collection point on CTU system including inter-operability requirements shall also be established by the concerned user as specified by CTU in the Connectivity Agreement.*

5.1 Real-Time Data Telemetry

Developer/Entity has to provide real time data of all parameters such as MW / MVAR, Voltage, State of Charge (SoC), Status (charge/discharge/idle), Alarms/Events etc. with resolution of 2-10 seconds (or better) to the respective SLDC (if connected to Intra-STTS) and with RLDC (if connected to ISTTS) through Redundant communication channels and appropriate communication protocol.

5.2 Remote Control

As per the clause-B2(5) of CEA Technical standards for connectivity to the grid,

- *“The generating stations of aggregate capacity of 500 MW and above shall have the provision to receive the signal from the State Load Dispatch Centre or Regional Load Dispatch Centre, as the case may be, for varying active and reactive power output”.*

In compliance to above regulations, BESS with capacity of 500 MW and above shall have capability for MW setpoint control, MVAR Setpoint control (Voltage control, PF control, reactive power control) from SLDC or RLDC.

5.3 AGC Compatibility

As per the clause-30(11)(x) of IEGC-2023,

- *“All renewable energy generating stations and ESS shall be equipped with the facility to control active power injection in accordance with the CEA Connectivity Standards and the communication system shall be established in accordance with the CEA Technical Standards for Communication”.*

In compliance to above regulations, AGC compatibility shall be ensured (where applicable).

5.4 PMU Placement

PMU shall be placed at the Point of Interconnection of BESS which shall be reporting the parameters like three phase voltage, three phase current, angles, frequency, active power and reactive power etc. and shall comply with CEA "Guidelines on Unified Philosophy for Placement of Phasor Measurement Unit (PMU) in Indian Grid" dated 19.03.2025.

5.5 Cybersecurity

BESS shall comply with CEA (Cyber Security in Power Sector) Guidelines, 2021 and any such regulations issued from time to time, by an appropriate authority

5.6 Communication Architecture

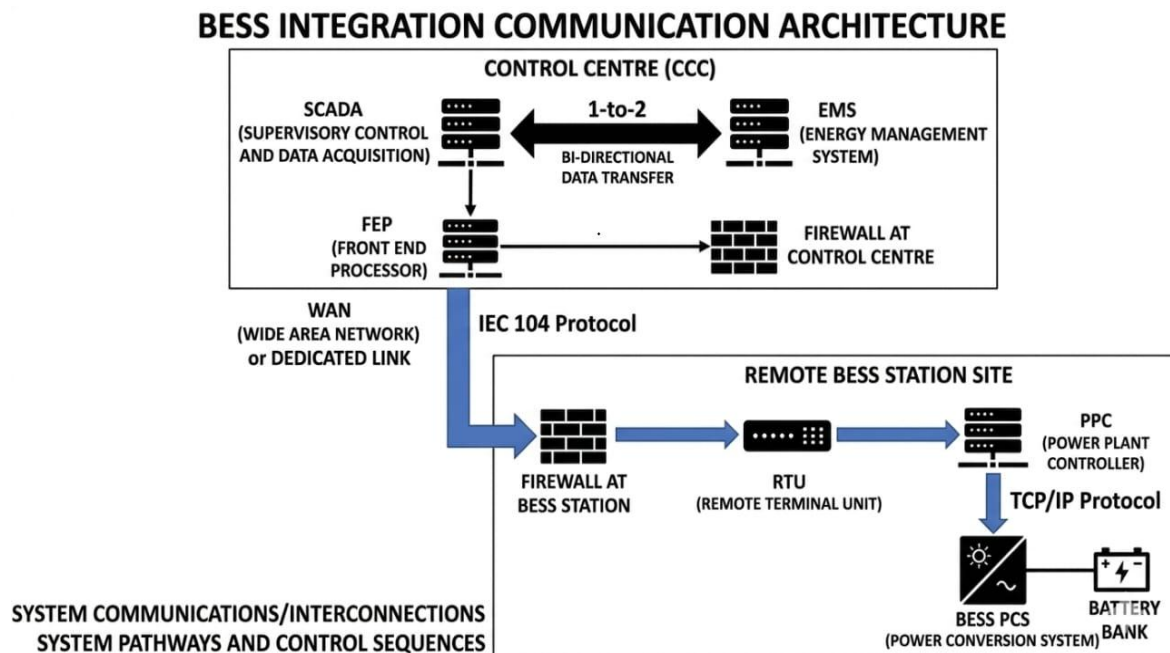

6. Safety Requirements

BESS shall comply with CEA (Measures Relating to Safety and Electric Supply) (Amendment) Regulations, 2026, issued vide notification dated 27.03.2026, incorporating safety provisions for Battery Energy Storage Systems (BESS). The same is placed at **Annexure-IV**.

7. Control of BESS from Control Centre

BESS signals should include the Signal List as provided in NLDC's Detailed Procedure for SRAS. The same is placed at **Annexure-III**.

It may be noted that these control signals may be used for any operational requirement.

8. FTC requirement for BESS

- a) GRID-INDIA's "Procedure for First Time Energization of Solar, Wind, BESS or Hybrid (Wind/Solar/BESS) Power Plants/Parks and Issuance of Certificate of Successful Trial Run" is enclosed at Annexure-1.
- b) GRID-INDIA's "Checklist for First Time Energisation and Integration of RE plants" is enclosed at Annexure-2.
- c) GRID-INDIA's "Guidelines for Power Plant Controller Function Testing of Renewable Energy Based Generating Station" is enclosed at Annexure-3.

9. Technical requirements

BESS shall comply with all applicable technical requirements specified under the CEA (Technical Standards for Connectivity to the Grid) Regulations, including provisions related to LVRT/HVRT capability, frequency response, reactive power support, and power quality standards such as harmonics, flicker, and voltage variations, as amended from time to time.

10. Compliances

All BESS installations shall comply with:

- CEA Technical Standards for Construction, the CEA Technical Standards for Connectivity, the CEA (Grid Standards) Regulations, 2010, the CEA Technical Standards for Communication and any other applicable CEA Standards specified from time to time
- CEA Technical Standards for Renewable Energy Plants—as and when they are notified
- Indian Electricity Grid Code (IEGC) 2023
- State Electricity Grid Code

NOTE: The inputs provided by TN SLDC are attached as Annexure for Reference.

BATTERY ENERGY STORAGE SYSTEMS (BESS)

As per IEGC 2023 Part 6, hybrid RE and storage resources require special consideration due to their dynamic operational characteristics, fast ramping capability and interaction with grid voltage/reactive power.

Therefore, before issuing connectivity approval, certain technical, operational, protection and compliance requirements must be validated to ensure grid safety, voltage stability, power quality and protection coordination in accordance with CEA & IEGC provisions.

2. Key Regulatory-Based Concerns Prior to Granting Grid Connectivity

a) Grid Security, Stability & Ramp Control

As per *IEGC 2023 Part 6, Clauses on Active Power Control & Ramp Rate*:

- Hybrid RE + BESS plants shall comply with mandated active power ramp limits, frequency control requirements, and must avoid sudden power surges or absorption.
- BESS operation shall not cause frequency excursion, uncoordinated charging or uncontrolled swings in output.
- As per CEA Grid Standards (2013), generating plants must operate without causing voltage fluctuations or disturbances.

b) Protection Coordination Requirements

As per *CEA Connectivity Standards (2013 & amendments)*:

- The fault contribution and inverter-based protection settings of Wind/Solar/BESS inverters must comply with LVRT/HVRT, anti-islanding, O/V–U/V, and O/F–U/F protection norms.
- Hybrid developers must furnish:
 - Fault-level calculations at 110/230 kV interface

- Relay coordination and grading study
- Islanding prevention scheme as per *CEA Grid Safety Regulations*.

c) Voltage Regulation & Reactive Power Support

As per *IEGC 2023 Part 6 (Voltage & Reactive Power Requirements)* and *CEA Connectivity Standards*:

- All inverter-based resources must operate within ± 0.95 power factor at the interconnection point.
- Plants must provide dynamic reactive power support, including night/SVC/STATCOM capability, as applicable.
- Inverter/IBR must support grid voltage during disturbances (LVVRT/HVRT).
- Hybrid developer shall furnish:
 - VAR sizing study
 - Capability curves of Solar, Wind and BESS inverters
 - Details of external VAR compensators

d) BESS SoC Management & Charge/Discharge Control

In line with MoP Draft BESS Standards 2023/24 and IEGC 2023 Part 6:

- SoC control logic, charge/discharge limits and operational philosophy must be declared in advance.
- BESS in charge mode must not draw power during low-voltage or contingency events, in accordance with the general grid-safety requirement under CEA Grid Standards.
- EMS/HPC must restrict injection to approved capacity and follow SLDC scheduling instructions.

e) Scheduling, Metering & Energy Accounting

As per *IEGC 2023 Chapter on Scheduling & CEA Metering Regulations*:

- Hybrid + ESS must adhere to 15-minute scheduling, QCA-based aggregation, and RE forecasting requirements.
- Separate meters are required for:
 - Solar Generation
 - Wind Generation
 - BESS Charging
 - BESS Discharging
 - Net Injection
- AMR/SCADA must comply with CEA Communication Standards 2020.
- COD certificate must confirm compliance with CEA Connectivity, Communication and Safety Standards.

f) Transmission Infrastructure Adequacy

As per *CEA Connectivity & Grid Standards*:

- Load flow studies must consider simultaneous Wind + Solar + BESS discharge.
- Transformer, bay equipment, CT/PT burden and STU substation ratings must be verified.

g) SCADA, Telemetry & Cybersecurity

As per *CEA Communication Standards (2020) & IEGC 2023*:

- Real-time data (MW, MVAR, SoC, inverter status, node voltages, alarms) must be provided to SLDC.

- BESS controller and HPC must comply with time-synchronization, redundancy & cybersecurity provisions.
-

3. Recommendations Prior to Issuing Grid Connectivity

The following documents and studies are obtained:

1. Hybrid plant design package
 - SLD, capability curves, VAR study, protection study, metering arrangement
2. Compliance report
 - IEGC 2023 Part 6
 - CEA Connectivity Standards
 - CEA Safety & Communication Regulations
3. SCADA/Telemetry readiness with SLDC
4. Installation of harmonic filters, STATCOM/VAR support and HPC
5. Load flow study demonstrating no overloading or voltage violation
6. Developer undertaking confirming that:
 - BESS will not charge without RLDC/SLDC approval
 - All SLDC instructions will be followed in real time
- 7. Battery Storage Support to Grid and DISCOM and recommendation of Best type of Battery in lieu with long life cycle and disposal mechanism shall be included in the Bid Document.**

1. BESS Control & Communication Architecture

The BESS operates through a four-level hierarchical control architecture:

Level	Layer	Key Functions
Level 4	Grid / SLDC Control	Real-time monitoring, dispatch & scheduling, BESS optimisation, ACE/frequency control, reserve management, congestion management
Level 3	Control Centre (SCADA/EMS)	SCADA: Data acquisition, alarms, event records. EMS: Forecasting, optimisation, dispatch. FEP: Protocol conversion, time sync. Cyber security.
Level 2	Plant Supervisory Layer	Central optimiser, SoC/SoH management, power dispatch, mode management (charge/discharge/standby), ramp rate, alarms, data logging
Level 1	Unit Control Layer	BMS: Cell monitoring, SoC/SoH estimation, cell balancing. PCS: Active/reactive power control, FFR/PFR, grid-forming/following. Protection IEDs.
Field	Equipment / Power System	Battery racks/modules, DC combiner, PCS/inverter, step-up transformer, MV switchgear, grid interconnection point

Communication protocols: IEC 60870-5-104 (SLDC/WAN), IEC 61850 / Modbus TCP (plant level), IEC 61850 (high-speed field level).

Key feedback signals include SoC, SoH, cell voltage/temperature, DC voltage/current, PCS P/Q/V/I, breaker status, alarms and weather/forecast inputs.

2. BESS Frequency Response – PFR & FFR

2.1 Operating Band and Deadband

- Nominal grid frequency: 50.000 Hz; Allowable operating band: 49.900 – 50.050 Hz.
- Deadband: ± 0.03 Hz (49.97 – 50.03 Hz) — BESS does not respond within this band.
- Droop setting (R): 3–5%; Deadband: ± 0.03 Hz; response symmetrical for over and under frequency.

2.2 Primary Frequency Response (PFR) – Droop Control

- Once frequency moves outside the deadband, droop control activates proportionally.
- Formula: $P_{\text{droop}}(f) = 50 \times (49.97 - f)$ for $f < 49.97$; $P_{\text{droop}}(f) = -50 \times (f - 50.03)$ for $f > 50.03$ (for 5% droop on 125 MW BESS \rightarrow slope = 50 MW/Hz).
- BESS injects power (discharges) for low frequency; absorbs power (charges) for high frequency.
- PFR responds within 1–10 seconds after the disturbance.

2.3 Fast Frequency Response (FFR)

- FFR acts almost instantaneously (100 ms – 1 s) to arrest frequency decline or rise.
- Triggered when $|df/dt|$ exceeds the RoCoF threshold (typically 0.5 Hz/s).
- Provides a fixed additional boost (approx. 18.75 MW on a 125 MW BESS) beyond the droop response.
- FFR is mandatory for Inverter-Based Resources (IBRs) as per CEA Connectivity Regulations.

2.4 Ancillary Service Timeline

- FFR: Fast arrest of frequency — 100 ms to 1 s.
- PFR (PRAS): Primary response to arrest & support — 1 to 10 s.
- SRAS: Restore frequency and reduce ACE — up to 15 min.
- TRAS: Replace secondary reserve support — up to 60 min.

2.5 SoC Window for Frequency Response

- Recommended operating SoC window: 20% – 80%.
- Ideal SoC for maximum flexibility: 40% – 60% (normal operating range).
- Above 80% SoC: Insufficient headroom to absorb power (high-frequency support unavailable).
- Below 20% SoC: Insufficient energy to inject power (low-frequency support unavailable).
- Reserve allocations (typical): PRAS 10–15%, SRAS 15–25%, TRAS 20–30% of BESS rated power.

2.6 Active Power Controller Block Diagram (Droop + FFR)

- Droop (PFR) Path: Measured frequency → Low Pass Filter → Deadband (± 0.03 Hz) → Droop Gain ($K_p = P_{max} / (R \times f_{nom})$) → Droop PI Controller → P_{droop} .
- FFR Path: d/dt (High Pass Filter) → RoCoF computation → FFR Trigger ($|df/dt| > \text{Threshold}$) → FFR Shaping (Fast Ramp – Hold – Ramp) → FFR Gain (K_{ffr}) → P_{ffr} .
- Combined output ($P_{droop} + P_{ffr}$) → Active Power PI (Plant Level) → Saturation Limiter ($\pm P_{max}$) → Rate Limiter → SoC Limiter → P_{ref} .

3. Automatic Generation Control (AGC) for BESS

- BESS receives AGC setpoint (ΔP_{AGC}) from SLDC EMS via SCADA/EMS interface (IEC 60870-5-104 / TCP-IP).
- BESS adjusts active power (charge or discharge) based on the AGC signal.
- Fast response: < 2 seconds; supports both up-regulation and down-regulation.
- AGC architecture uses Area Control Error (ACE) calculation: $ACE = (P_{actual} - P_{schedule}) + B \times (f - 50)$.
- Two-area model: SLDC/AGC controller manages tie-line dynamics ($\Delta P_{tie,12}$) and frequency deviation (Δf).
- BESS as AGC participant provides fast, precise regulation and improves frequency stability and reliability.

4. Reserve Management

4.1 Concept

- Up Reserve: Additional capacity available above scheduled generation to handle demand increase or generation trip.
- Down Reserve: Absorption capacity available below scheduled generation to handle generation surplus.
- BESS reserves should not be normally scheduled for routine operations; reserved only for contingencies.

4.2 Normal Condition (Reserves Adequate)

- Available Up Reserve \geq Mandated Up Reserve Requirement → system is secure.
- Available Down Reserve \geq Mandated Down Reserve Requirement → system is secure.
- BESS is NOT obligated for reserve and can be used for DSM, market operations, peak support, etc.

4.3 Reserve Shortfall Condition (Example: Mylatti 125 MW BESS)

- Up Reserve Shortfall: Mandated 300 MW; Generators provide 240 MW → Shortfall = 60 MW.
- SLDC instructs BESS to keep 60 MW earmarked as Up Reserve. Remaining BESS capacity for other uses = 65 MW.
- Down Reserve Shortfall: Mandated 200 MW; Generators provide 150 MW → Shortfall = 50 MW.
- SLDC instructs BESS to keep 50 MW charging headroom (absorption capability) as Down Reserve. BESS SoC maintained at 40–60%.

4.4 Combined Reserve Margin Example

- BESS capacity = 125 MW. Total reserve margin (Up + Down) required = 80 MW. Remaining for energy operations = 45 MW.
- SoC must be maintained in mid-range (40–60%) for bi-directional readiness.
- Reserved capacity released ONLY for real-time contingency events (FFR/Droop/Contingency).

5. DSM (Deviation Settlement Mechanism) / ACE Management

5.1 Key Concepts

- DSM: Financial penalty for deviating from schedule. ACE: Real-time control signal.
- $ACE = (P_{\text{actual}} - P_{\text{schedule}}) + B \times (f - 50)$. $ACE > 0$ → excess generation (BESS charges); $ACE < 0$ → deficit (BESS discharges).

6. Peak Demand Management

- Concept: Charge BESS during off-peak / low demand; discharge during peak / high demand.
- Charging Energy Requirement: To deliver 500 MWh during peak, total input energy = $500 / 0.90 \times 1.02 \approx 567$ MWh.
- Charging Schedule (off-peak 6 hours): Required charging power = $567 / 6 \approx 94.5$ MW → Charge C-rate = 0.19C (within limit).
- Discharge Schedule (peak 4 hours, 18:00–22:00): Discharge power = $500 / 4 = 125$ MW → C-rate = 0.25C (within limit).
- Result: Peak demand reduced by 125 MW; load curve flattened; DSM penalty avoided.
- SLDC finalises block-wise (15-min interval) input/output energy schedules considering RTE, C-rate and Aux Consumption.

7. Market Operation (DSM Rate-Based Economic Dispatch)

- During the first volume limit of DSM (small ACE), BESS can operate based on DSM rates for economic optimisation.
- Deficit + High DSM price → BESS discharges (injects power) to reduce deviation and avoid penalty.
- Deficit + Low DSM price → BESS may conserve SoC for critical events.
- Surplus + Low/Negative DSM price → BESS charges (absorbs power) economically.
- Layered strategy: Small deviation → Economic operation (DSM rate-based); Moderate → Partial correction; Large → Full correction (system security priority).

8. Congestion Deployment by SLDC

8.1 Congestion due to Excess Power Flow (Over-generation)

- BESS charges (absorbs power) at highest C-rate to reduce flow on the congested corridor.

8.2 Congestion due to Power Deficit / Reverse Flow

- BESS discharges (injects power) at highest C-rate to reduce dependency on the congested corridor.

8.3 Evacuation / Transmission Constraint

- BESS deployed for evacuation/transmission constraint must prioritise handling the constraint.
- If no constraint exists in real time, BESS can be re-purposed for peak shaving, market operations, reserve provision, or DSM support.
- Constraint status continuously monitored in real time by SLDC/RLDC.

9. Phasor Measurement Unit (PMU) Integration

- PMU installed at Point of Interconnection (POI); provides high-speed (25/50 samples/sec), time-synchronized measurements.
- Measured parameters: 3-phase voltage, 3-phase current, frequency, RoCoF, voltage/current phasor angle (δ), active power (P), reactive power (Q), UTC time.
- PMU data stream (IEEE C37.118 / IEC 61850-90-5) transmitted to PDC/Phasor Data Concentrator → SLDC/WAMS.

- Applications: Real-time grid monitoring, frequency & RoCoF monitoring, oscillation detection & damping, voltage stability assessment, dynamic state estimation, event detection & post-event analysis.
- Time synchronization via GPS / IRNSS.

10. Fault Ride Through (FRT) and Black Start

10.1 LVRT and HVRT Compliance

- BESS must comply with CEA 2019 Fault Ride Through (VRT) standards.
- LVRT: BESS must remain connected and support grid during voltage dips down to ~0.2 p.u. for up to ~0.625 seconds, then recover.
- HVRT: BESS must withstand over-voltage (up to ~1.3 p.u.) without tripping.
- BESS response must remain within the CEA Continuous Operation Zone during and after the fault.

10.2 Black Start – Grid-Forming (GFM) Capability

- GFM-capable BESS can perform black start restoration from 'cold start' (0 p.u. voltage).
- Sequence: Cold Start → GFM Voltage Source established → Bus Pressurize → Load Step (Steady State) → Grid Sync.
- Internal voltage rises rapidly to ~0.6 p.u. at cold start; system frequency stabilises at ~50 Hz throughout the sequence.
- Black start is enabled only where specified in the contract and required by the System Operator.

11. System Operation – Centralised BESS Optimisation at SLDC

- BESS can be operated by manual entry by System Operator (charge/discharge power MW, schedule, mode, priority) or through centralised dispatch via BESS Optimiser at SLDC.
- With multiple BESS at various locations, centralised optimisation is essential to avoid counter-dispatches among BESS units.
- SLDC BESS Optimiser: Aggregates data from all BESS, runs optimisation engine, handles constraints, generates coordinated schedules.
- Objectives may include: Peak Demand Management + ACE; Peak Demand Management + Market-Based; Congestion Management + Reserve Provision; or other combinations.
- Limiting constraints in optimisation: BESS technical limits (MW/MWh/SoC/ramp/C-rate), operational constraints (min/max SoC, efficiency/losses), time & schedule constraints, grid constraints (transmission/congestion/security), policy/market constraints (DSM rules, reserve requirements, regulatory directives).

12. Communication Architecture

- IEC 60870-5-104 (IEC 104): Between Control Centre (SCADA) and remote BESS Station (RTU) — via WAN or dedicated link.
- TCP/IP Protocol: Between RTU, PPC (Power Plant Controller), PCS and BESS equipment at the site.
- Data flow: Telemetry / Status / Alarms / Measurements from BESS to Control Centre; Control Commands / Setpoints / Dispatch from Control Centre to BESS.
- Firewall and cyber security at both Control Centre and BESS Station ends.
- Architecture enables secure bi-directional communication between SLDC and all BESS stations.